

2x4-M6 TAP x 12 Deep
(Face A,B)

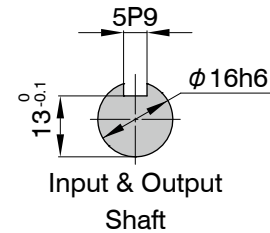

The keyway position of the input shaft in the drawing suggests the center of dwell period.

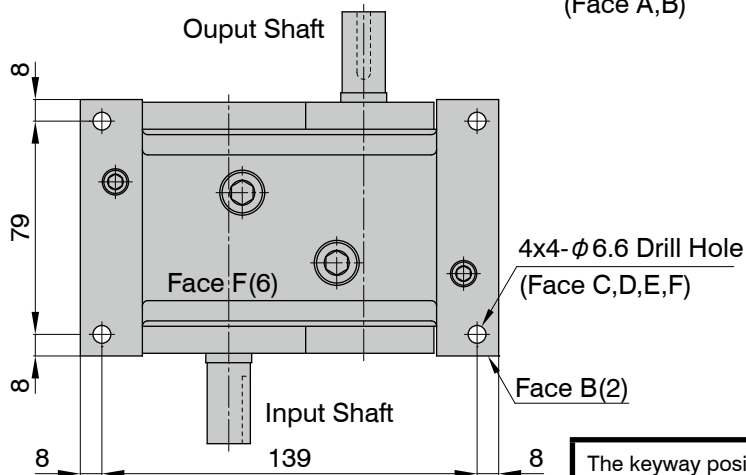

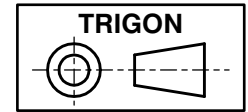
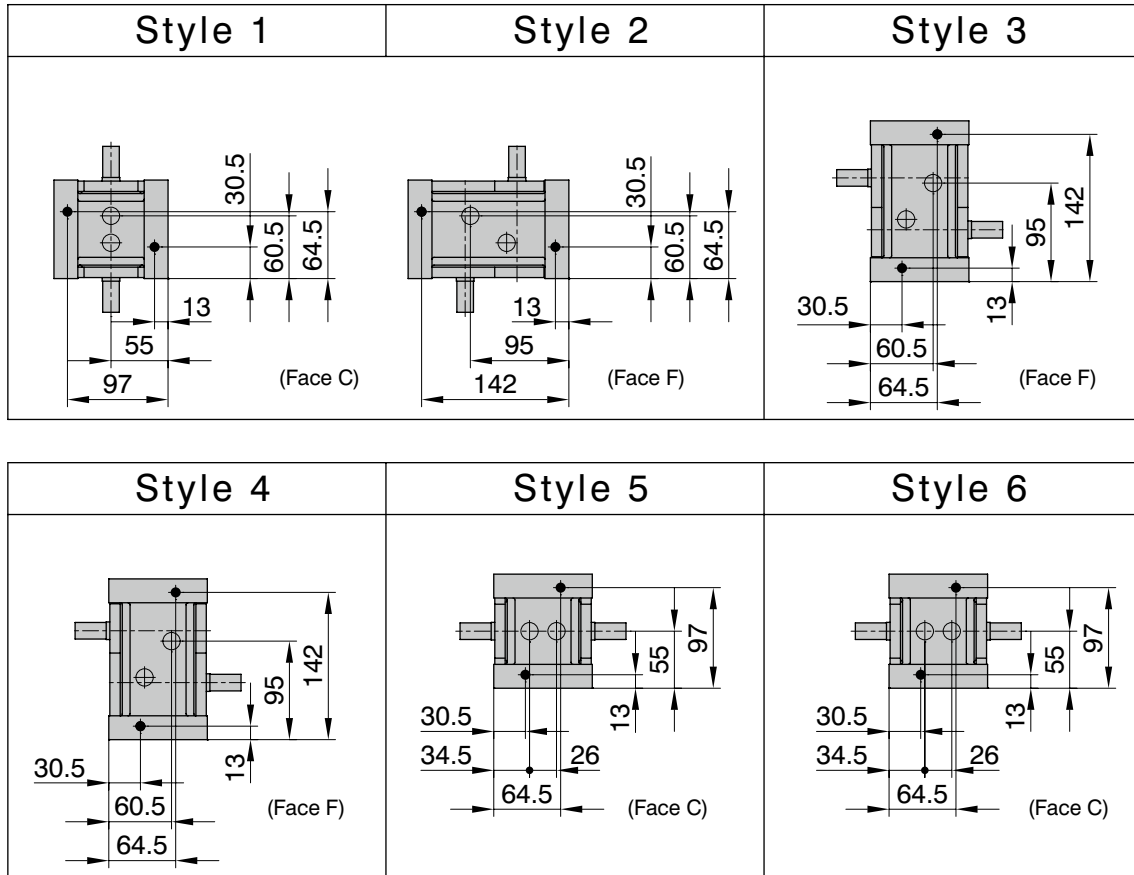

Additional Information	
Filler, Drain (black circle)	Rc1/8
Level (white circle)	Rc3/8
Rough Product Weight	4.1kg
Rough Lubricating Oil Capacity	0.3 Liters
Mounting Tapped Holes	Face A & B
Mounting Through-holes	Face C - F

PI-50S
OM1-4IK25GNST/4GN □ K

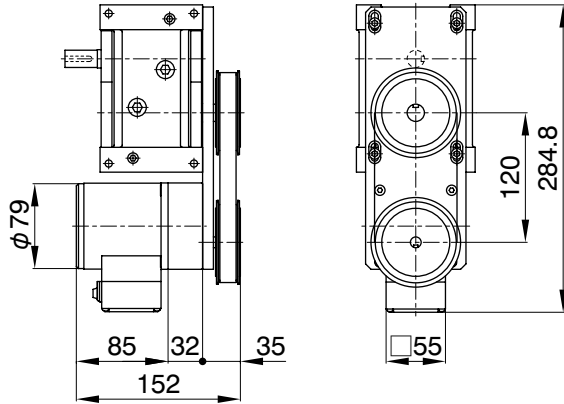

PI-50S
OM1-CBI425-703T/4GC □ K

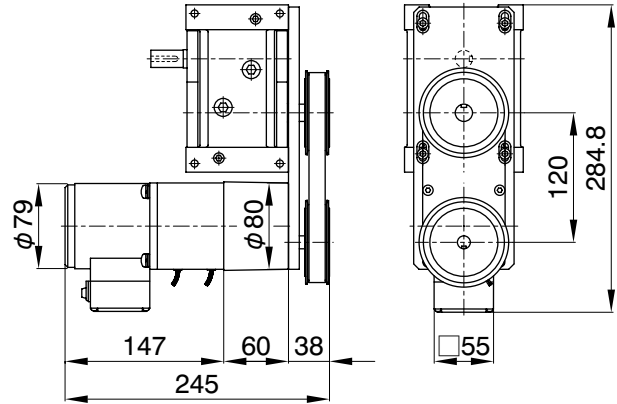

PI-50S
TB-322

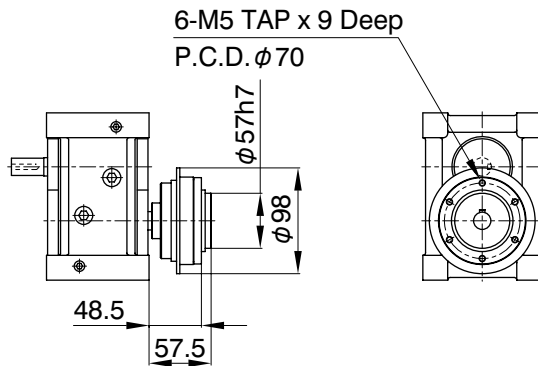

PI-50S
TA-332

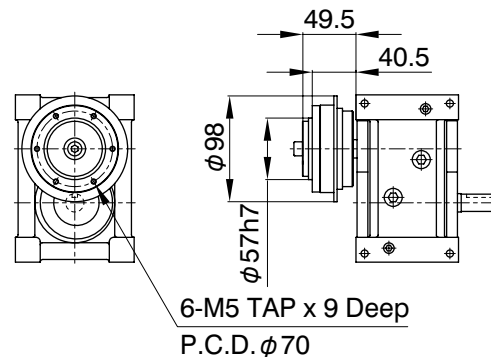

Additional Notes

- Various types of an AC standard small-sized motor can be mounted.
- Mounting positions of an AC standard small-sized motor is standardized as 4 different pattern.
- MYTORQ torque limiter 300 series can be mounted.
- Autoflex couplings can be mounted.
- Autogard torquelimiter 400 series or Autoflex couplings can be mounted on the input shafts of a worm reducer.