

Style A	Style B	Style C
		
Style D	Style E	Style F
		

Additional Information	
Filler, Drain (black circle)	Rc3/8
Level (white circle)	Φ30
Rough Product Weight	32kg
Rough Lubricating Oil Capacity	1.2 Liters
Mounting Tapped Holes	Machining the specified faces upon request

# RI/RO-90F

## Mounting Examples of Optional Parts

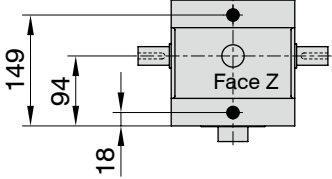
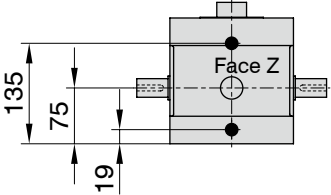
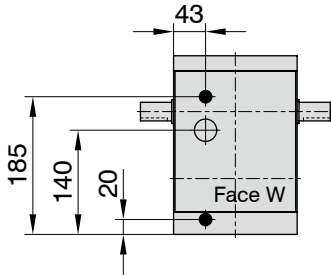
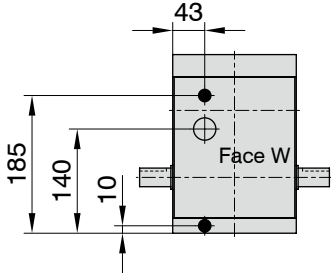
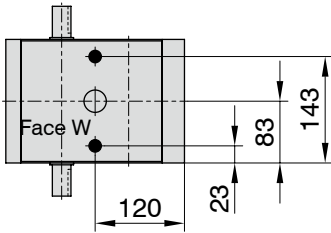
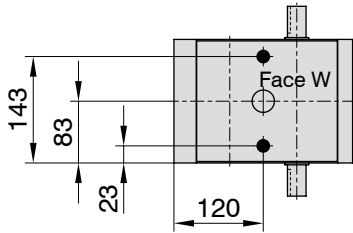
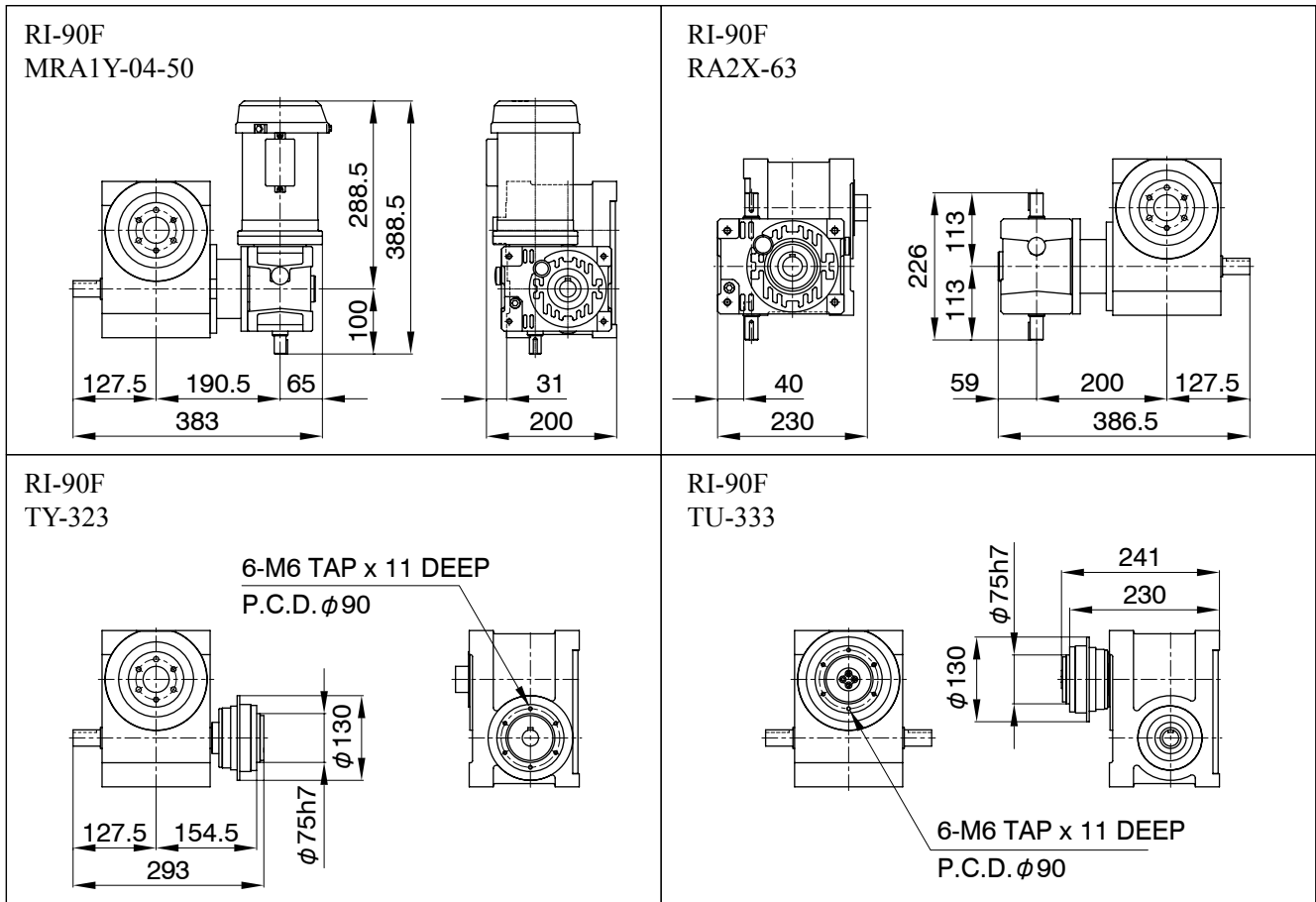

### Additional Notes

- MA series worm reducer MAO50 and 63 can be mounted.
- Mounting positions of a drive unit is standardized as 16 different pattern.
- MYTORQ torque limiter 300 series can be mounted.
- Autoflex couplings can be mounted.
- Autogard torquelimiter 400 series or Autoflex couplings can be mounted on the input shafts of a worm reducer.