

### Part Names

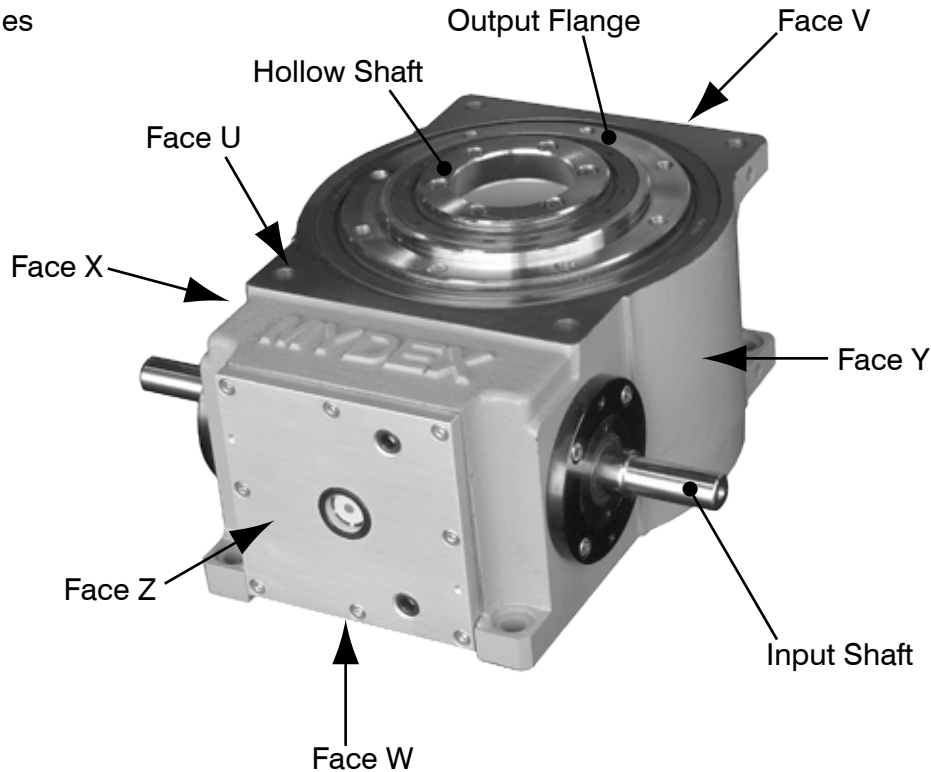

### Note

1. MS (Modified Sine) is standardized in all cam motion law (with few exceptions), but please instruct in advance or consult us if a specified cam motion law or special one is required.
2. Please instruct us only if TH cam and TD cam are required.
3. Please instruct in advance or consult us if you require the number of stops which is not described in the catalog.
4. Please specify in advance or consult us if you require an index angle or timing which is not described in the catalog.
5. Please confirm carefully the direction of the input and output shafts to decide on cam handing.
6. Mounting positions of TLX series are basically style B. Please consult us in advance if you use it on the other styles.
7. Please consult us if you need to change the dimensions, etc. of the input and output shafts that are not shown in the catalog.
8. The faces of mounting tapped holes are basically as follows.  
Tapped holes on face U and mounting holes on face W :TLX100 - 175 (Total 4 sizes)  
Tapped holes on specified faces upon request :TLX254 or above sizes (Total 4 sizes)
9. In TLX254 or bigger sizes, please note that the mounting tapped holes or the mounting holes cannot be machined at both face UW and VZ.
10. Machining positions of oil plugs (Oil filler, level, drain) are basically standardized as follows.  
Style A, B: Machining at face Z  
Style C, D: Machining at face W  
Please consult us if you require machining at the other faces.
11. If you need the specifications which are not shown in the catalog, please be sure to confirm the possibility of manufacturing.